

HUBA_Level / pressure monitoring



SENSOR FUNCTIONS

This module is an ATEX device for monitoring liquid level by pressure difference. It also measures the temperature of the liquid. It enables you to avoid stock-outs and anticipate replenishment.

The sensor communicates only via the proprietary HR-Net protocol. To send data over the cellular network, it must be paired with one of the HR-Net/4G gateways below:

- CR100 Gateway (220V external power supply, 4G-Data)
- CR110 Gateway (Battery-powered, 4G - SMS)

Information can be viewed directly on the Desk & Sens platform and notifications, **email or SMS alerts can be set up.**



TECHNICAL SPECIFICATIONS OF THE SENSOR

Model	Value	Model	Value
Power supply	Lithium battery	Dimensions	80 x 67 x 163 mm
Battery life	Around 10 years	Net weight material	350 g
Network	HR-Net	Operating T°	-10°C;+40°C
Maximum transmit power	12 dBm +/- 2 dBm	Protection class	IP 68
Maximum sensitivity	- 105 dBm	Cable length	5 et 15 mètres
Frequency of readings	- With CR110: 2 daily readings - With CR100: 1 reading/hour	Certifications	RED Directive: 2014/53/EU
Measurement type	Pressure (dBm)		RoHS II Directive: 2011/65/EU
Compatible fluids	Fuel oil, lubricants, diesel, petrol, AdBlue. <i>Consult us for other other liquids.</i>		ATEX Directive: 2014/34/EU
			ATEX marking : II 2(1) G Ex ia IIB T4 for TANKL PRH ZO

USE CASES

Remote monitoring of the liquid level in a tank with an ATEX atmosphere.

Configurable level alerts depending on the monitoring system (consumption or fill monitoring) received by SMS or email (or both).

A history enables you to trace the evolution of your tank levels over the last month/week/day (or customised date).

ADVANTAGES OF THE SENSOR

Easy remote monitoring of equipped sites from a professional interface.

Rapid identification of product shortages and implementation of a rapid restocking system.

Traceability and history of requests and actions at each site.

Alert system (email, SMS and push notification) to warn technicians/site managers to avoid stock-outs.

Create an order directly from your interface.

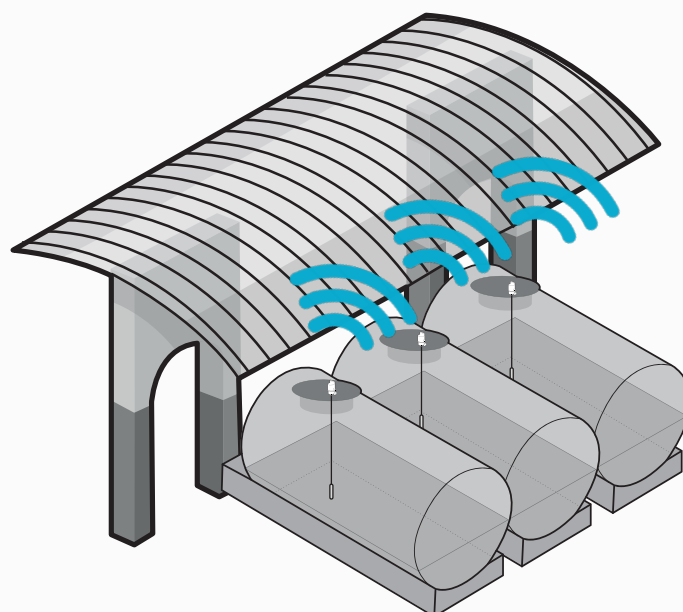

BUSINESS INFORMATION

Commercial designation	Product name	Item code
Huba Cable Module 5M 0.5% accuracy	HUBA-CABLE-5M-V2-868 ATEX	[CEMDGU203496]
Huba Cable Module 15M precision 0,5%	HUBA-CABLE-15M-V2-868 ATEX	[PRIPGU404215]